

# Zino

《User Manual》

Version 2.0



## **Disclaimer & Warning**

All users must read product operating instructions as well as this liability disclaimer before using any Hubsan product. By using a Hubsan product(s), users are accepting the terms and conditions of Hubsan liability and operational guidelines. This product is not suitable for minors under 14 years of age. While operating a Hubsan product(s), users also accept all liability and responsibility for their own behavior, actions as well as any consequences resulting thereof while using a Hubsan product(s). These products may only be used for purposes that are proper and in accordance with local regulations, terms and any applicable policies / guidelines Hubsan may make available. Users agree to comply with these terms and conditions, along with any and all relevant policies / guidelines set forth by Hubsan.

## **Instructions**

Some product flight functions are restricted in certain areas. Once you use this product, you are deemed to have read carefully the relevant ICAO regulations, local airspace control provisions and the regulations governing UAVs. You assume all liability for any non-compliance with the foregoing, are responsible for the consequences for your actions as well as any indirect and / or direct liability that arises as a result of these limitations.

## **Flight environment requirements**

- (1) Select an open environment devoid of high rise buildings and tall obstructions (such as trees and poles). Near buildings and obstacles, flight control signals and GPS signals can be severely weakened; GPS functions such as GPS mode and Return to Home may not function properly.
- (2) Do not fly in bad weather conditions (such as in wind, rain or fog).
- (3) Fly the aircraft in ambient temperatures of 0-40 °C.
- (4) When flying, please stay away from obstructions, crowds, high voltage lines, trees, water, etc.
- (5) To avoid remote control signal interference, do not fly in complex electromagnetic environments (such as venues with radio stations, power plants and towers).
- (6) The aircraft cannot be used in or near the Arctic circle or Antarctica.
- (7) Do not fly in no-fly zones.
- (8) Do not operate the aircraft near high pressure lines, airports or areas with severe magnetic interference.



# IMPORTANT SAFETY INFORMATION

## OPERATION

Be extremely careful and responsible when using the aircraft. Small electronic components can be damaged due to crashes or exposure to moisture / liquid. To avoid any injuries, do not use the aircraft with broken or damaged components.

## MAINTENANCE

Do not try to open or repair the units by yourself. Please contact Hubsan or Hubsan authorized dealers for service. For more information, please visit the official website at [www.hubsan.com](http://www.hubsan.com).

## BATTERY

Do not disassemble, squeeze, impact, burn, drop or trample the battery. Do not short-circuit or put the battery terminal in contact with metal. Do not expose the battery to temperatures above 60 ° C. Charge the aircraft battery prior to flight. Use a Hubsan dedicated charger for charging. Keep the battery out of the reach of children and away from any kind of moisture.

## FLIGHT

Please be mindful of personal safety and the safety of others while flying.

- Do not fly in bad weather conditions.
- Do not attempt to catch the aircraft while it is in flight.
- This product is intended for experienced pilots over the age of 14.
- After every flight, completely disarm the aircraft motors and disconnect the aircraft from power. Then, you may power off the remote control.

**READ THE DISCLAIMER AND SAFETY GUIDELINES FIRST BEFORE USE.**

## Symbol Explanation:

 Prohibited Operation

 Instruction

 Important Notice

 Explanation / Reference

## USAGE ADVICE

(Hubsan has created the following operational and safety materials):

 Quick Start Guide



# IMPORTANT SAFETY INFORMATION

## Hubsan Safety Advisory Notice for Lithium-Polymer (LPO) Batteries

LiPo batteries are different from conventional batteries in that their chemical contents are encased in a relatively lightweight foil packaging. This has the advantage of significantly reducing their weight but it does make them more susceptible to damage if roughly or inappropriately handled. As with all batteries, there is a risk of fire or explosion if safety practices are ignored:

- If you do not plan to fly the aircraft for a long time, store the battery ~50% charged to maintain battery performance and life.
- Please use Hubsan chargers for battery charging.
- Discharge the battery at 5C current or below. To avoid discharge related battery damage, do not prolong the discharge time.
- Do not charge on carpet to avoid fire.
- Batteries need to be recharged if unused for over 3 months.

- ⊘ 1. Do not disassemble or reassemble the battery.
2. Do not short-circuit the battery.
3. Do not use or charge near sources of heat.
4. Do not put the battery in contact with water or any kind of liquid.
5. Do not charge batteries under sunlight or near fire.
6. Do not puncture or subject the battery to force of any kind.
7. Do not throw or manhandle the battery.
8. Never charge a battery that has been damaged, become deformed or swelled.
9. Do not solder on or near the battery.
10. Do not overcharge or over discharge the battery.
11. Do not reverse charge or reverse the battery polarities.
12. Do not connect the battery to a car charger / cigarette lighter or any kind of unconventional power source.
13. This battery is prohibited for non-designated devices.
14. Do not touch any kind of liquid waste or byproduct from batteries. If skin or clothes come in contact with these substances, please flush with water!
15. Do not mix other types of batteries with lithium batteries.
16. Do not exceed the specified charging time.
17. Do not place the battery in a microwave or in areas of high pressure.
18. Do not expose the battery to the sun.
19. Do not use in environments with high static electricity (64V and above).
20. Do not use or charge in temperatures below 0 °C and above 45 °C.
21. If a newly purchased battery is used, leaking, possesses a bad smell or other abnormalities, return immediately to the vendor.
22. Keep away from the reach of children.
23. Use a dedicated battery charger and follow all charging requirements.
24. Minors who use the battery and its dedicated unit must be supervised by an adult at all times.



# Table Of Contents

Important Safety Information -	1	<b>4. Flight</b> -----	9
Symbol Explanation -----	1	4.1 Pre-Flight Checklist -----	9
Usage Advice -----	1	4.2 Pairing The Mobile Device -	9
<b>1. The Aircraft</b> -----	4	<b>4.3 Calibration</b> -----	11
1.1 Aircraft Component Breakdown -----	4	4.3.1 Horizontal Calibration -	11
1.2 Charging and Installing the Aircraft Battery -----	4	4.3.2 Compass Calibration --	11
1.3 Installing & Uninstalling the Aircraft Propeller -----	5	4.3.3 GPS Accuracy Test ---	11
1.4 Aircraft LED Indications --	5	4.4 Flying with the APP -----	13
<b>2. X-Hubsan APP</b> -----	6	4.4.1 Auto Takeoff / Land --	13
2.1 App Overview -----	6	4.4.2 Advanced Functions -	13
2.2 Downloading the X-Hubsan App -----	6	4.5 Flying with the HT016B Transmitter -----	17
2.3 Main Interface Guide ---	6	<b>5. Failsafe</b> -----	21
<b>3. The HT016B Transmitter</b> --	7	5.1 Low Power Failsafe -----	21
3.1 HT016B Function Breakdown -----	7	5.2 Loss Of Flight Control Failsafe -----	21
3.2 Transmitter Cable Connection -----	7	<b>Frequently Asked Questions</b> -	22
3.3 HT016B Function Breakdown -----	8	<b>Parts &amp; Accessories</b> -----	23
3.4 Charging the Transmitter Battery -----	8		



# 1 Aircraft

## 1.1 Aircraft Component Breakdown

1. Propeller A
2. Propeller B
3. LED indicator
4. Motor
5. Body shell
6. 4K HD Camera
7. Micro-SD / TF Slot
8. Gimbal
9. Power
10. Gimbal Protection Guard

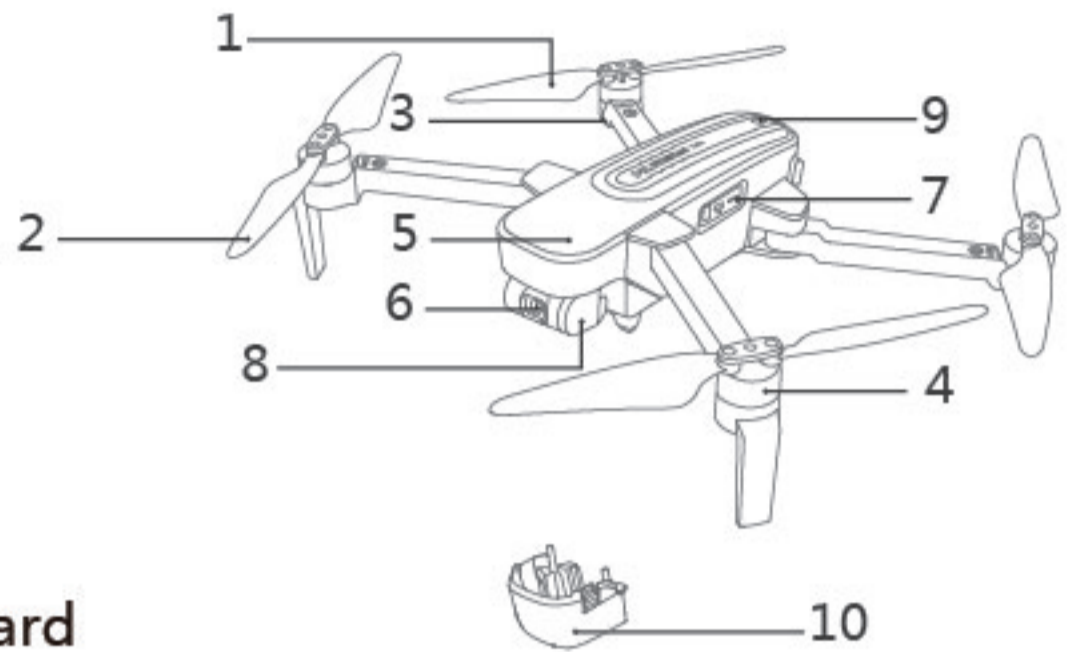

## 1.2 Charging and Installing the Aircraft Battery

### Charging:

Take out the aircraft battery and connect it to the balance charger and adapter.

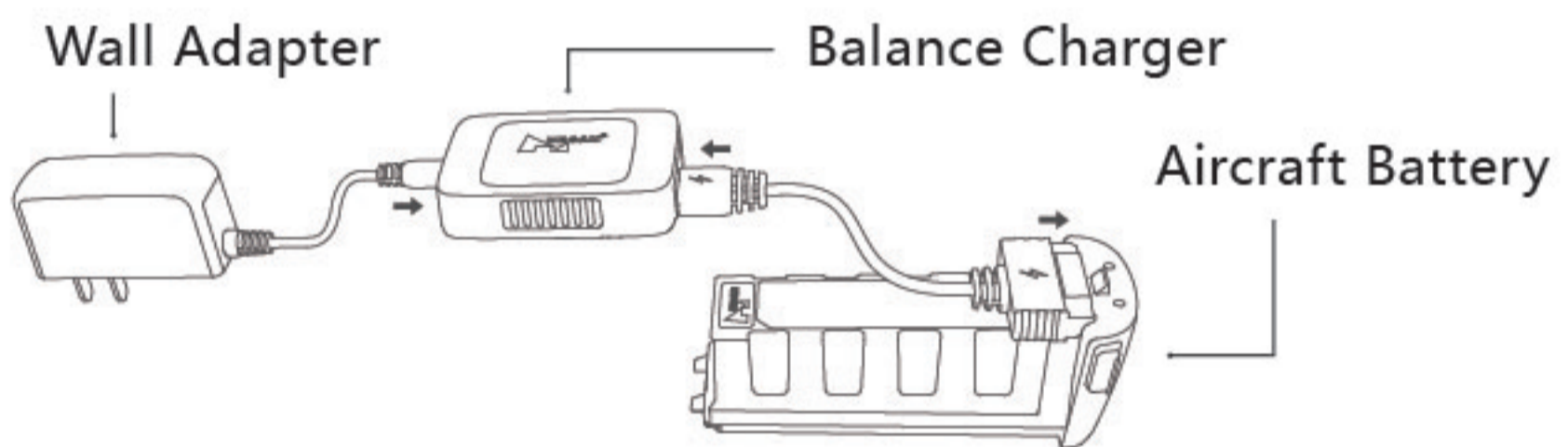

While charging, the balance charger LEDs will be solid red. When charging is complete, the LEDs will be solid green.

### Installation :

Extend the front arms first then extend the rear arms to the maximum angle. Pinch the sides of the battery and push the battery in until you hear a click. Make sure the battery is locked in. To remove the battery, hold the head of the aircraft and pinch the sides of the battery then pull the battery out.

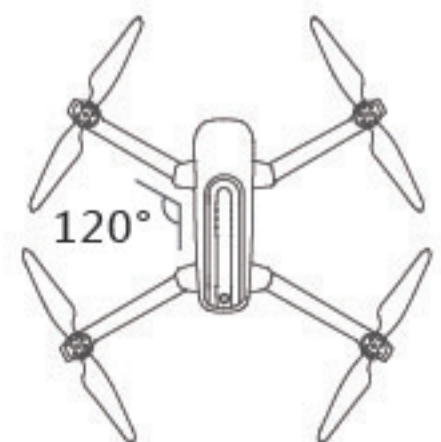



## 1.3 Installing & Uninstalling the Aircraft Propeller

Before installing propellers for the first time, please check that each Propeller A is matched with motor A and each Propeller B is matched with motor B. Then use the provided screws to secure each propeller. Tighten the screws clockwise to install them. When the propellers need to be replaced, unscrew the propellers by loosening the screws counterclockwise and then removing the damaged propellers.

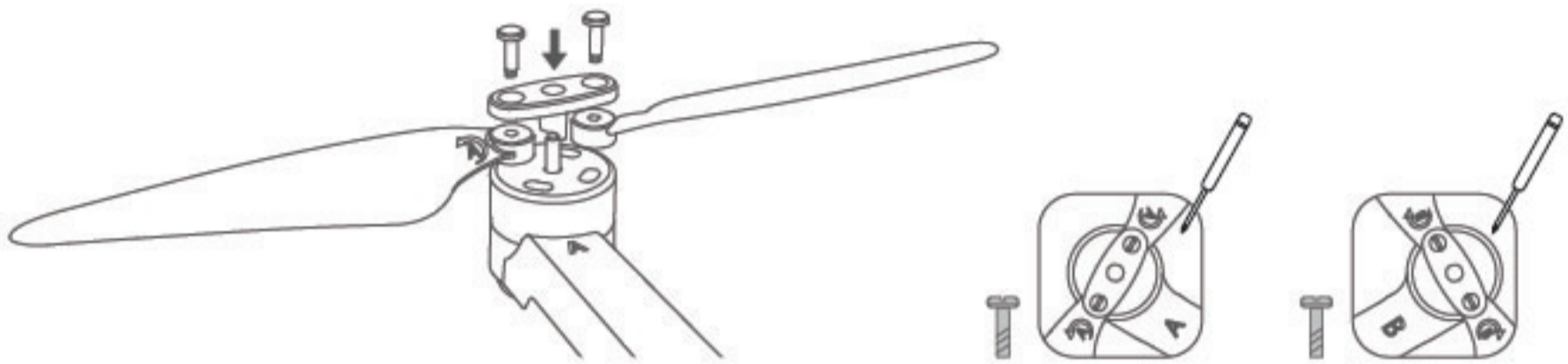

## 1.4 Aircraft LED Indications

Zino has 4 LEDs; the fore / frontal LEDs are blue and the rear LEDs are red. The LED status indications are defined as follows:

Function		LED status indication
Power On And Start Up		All 4 LEDs flash slowly
Horizontal Calibration		All 4 LEDs flash slowly
Compass Calibration	Calibrate Compass 1 Calibrate Compass 2	LEDs flash in vertical pairs, alternately All 4 LEDs flash simultaneously
Flight mode		All 4 LEDs are solidly lit
Low Power		Fore / frontal blue LEDs stay solidly lit and the rear red LEDs flash rapidly
Headless Mode		Fore / frontal LEDs are solid blue and rear red LEDs flash alternately
Return To Home		Fore LEDs are solid blue and rear LEDs slowly flash red
Photo		Rear red LEDs flash once
Video		Rear red LEDs flash alternately
Flight Control Connection Status		When the aircraft is not connected to a transmitter or has been disconnected from a transmitter, the fore LEDs will flash blue. Upon connection with a transmitter, the fore LEDs will turn solid.



## 2 X-Hubsan App

### 2.1 APP overview

X-Hubsan is a flight control APP designed for HUBSAN WIFI-enabled aircraft. Users can control the flight, camera, video and flight parameters with the APP. It is recommended to use a smart device with a large screen for the optimal visual experience.

### 2.2 Downloading the X-Hubsan App

Before flying, users must download the X-Hubsan APP.

Download the APP for free by scanning the code on the right or by downloading it via the App Store (iOS) and Google Play (Android).



### 2.3 Main Interface Guide

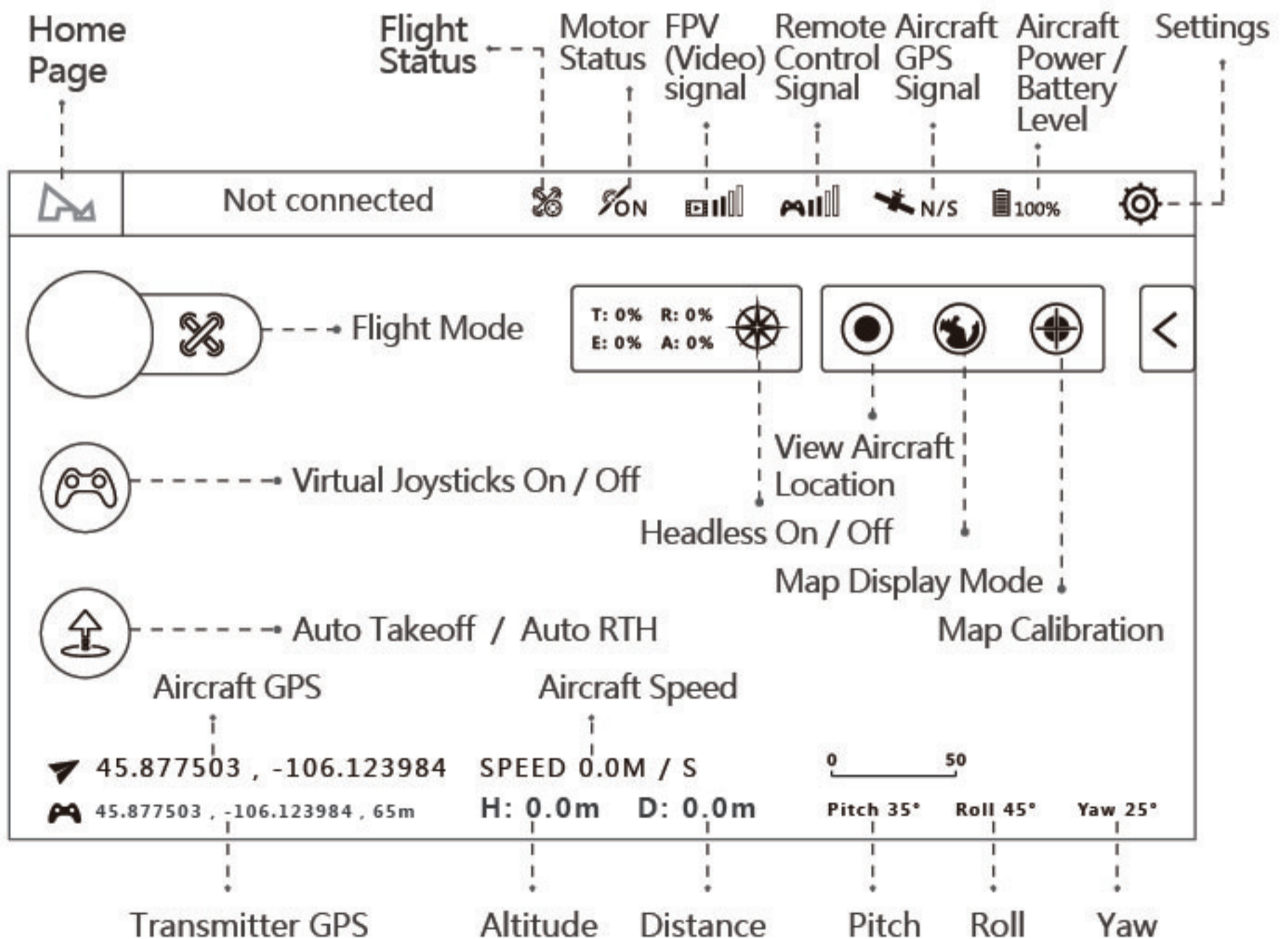

(Note: This interface is the interface in map mode.)



## 3 The HT016B Transmitter

### 3.1 HT016B Function Breakdown

- (1). Throttle / Aileron stick
- (2). Elevator / Rudder stick
- 1. Throttle / Rudder Joystick
- 2. Elevator / Aileron Joystick
- 3. Return To Home (Aircraft Returns To Takeoff Point)
- 4. Power (Long press)
- 5. Auto Takeoff / Land
- 6. Expert / Normal Mode
- 7. Power Status LEDs
- 8. Photo
- 9. Video
- 10. Gimbal Adjustment Wheel
- 11. Charging / Adapter Port
- 12. WIFI Antenna
- 13. Adapter Cable

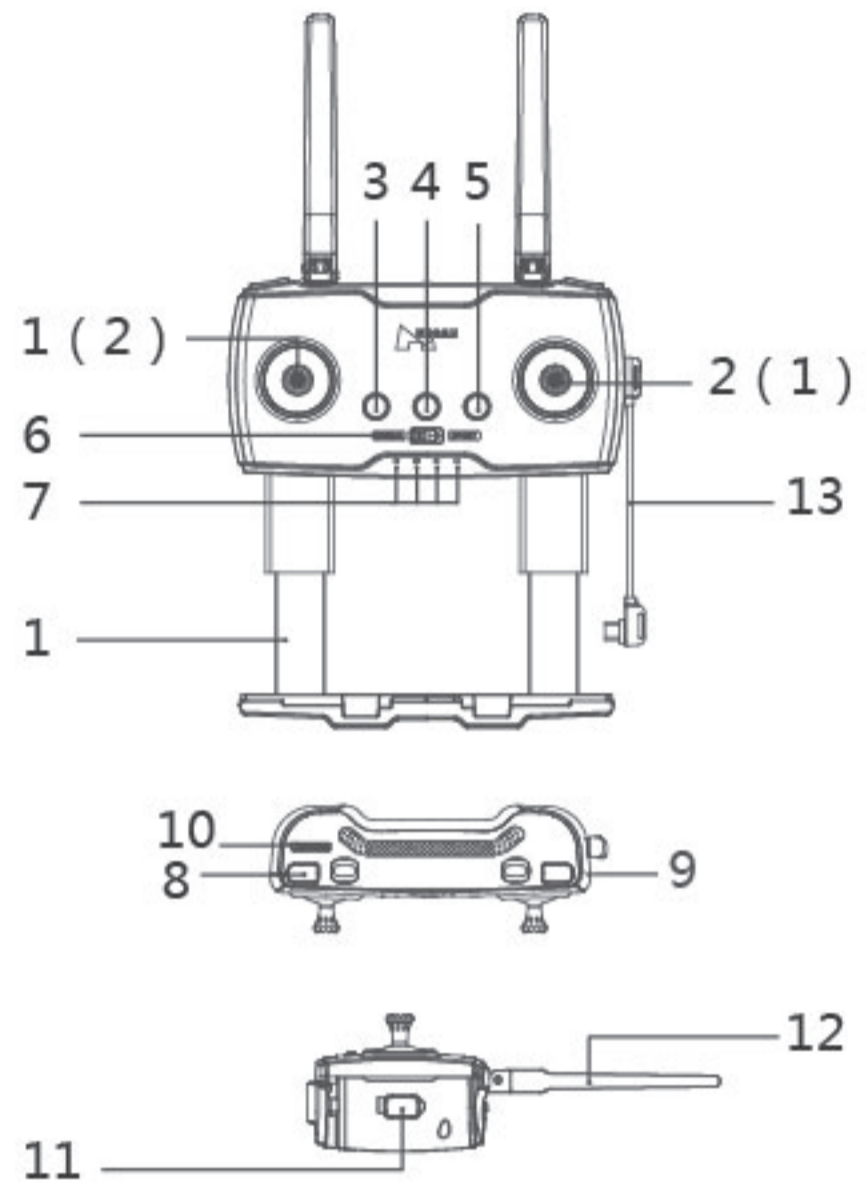

When installing the mobile device, place the device in its dedicated frame and avoid pressing the device's buttons with the frame.

### 3.2 Transmitter Cable Connection

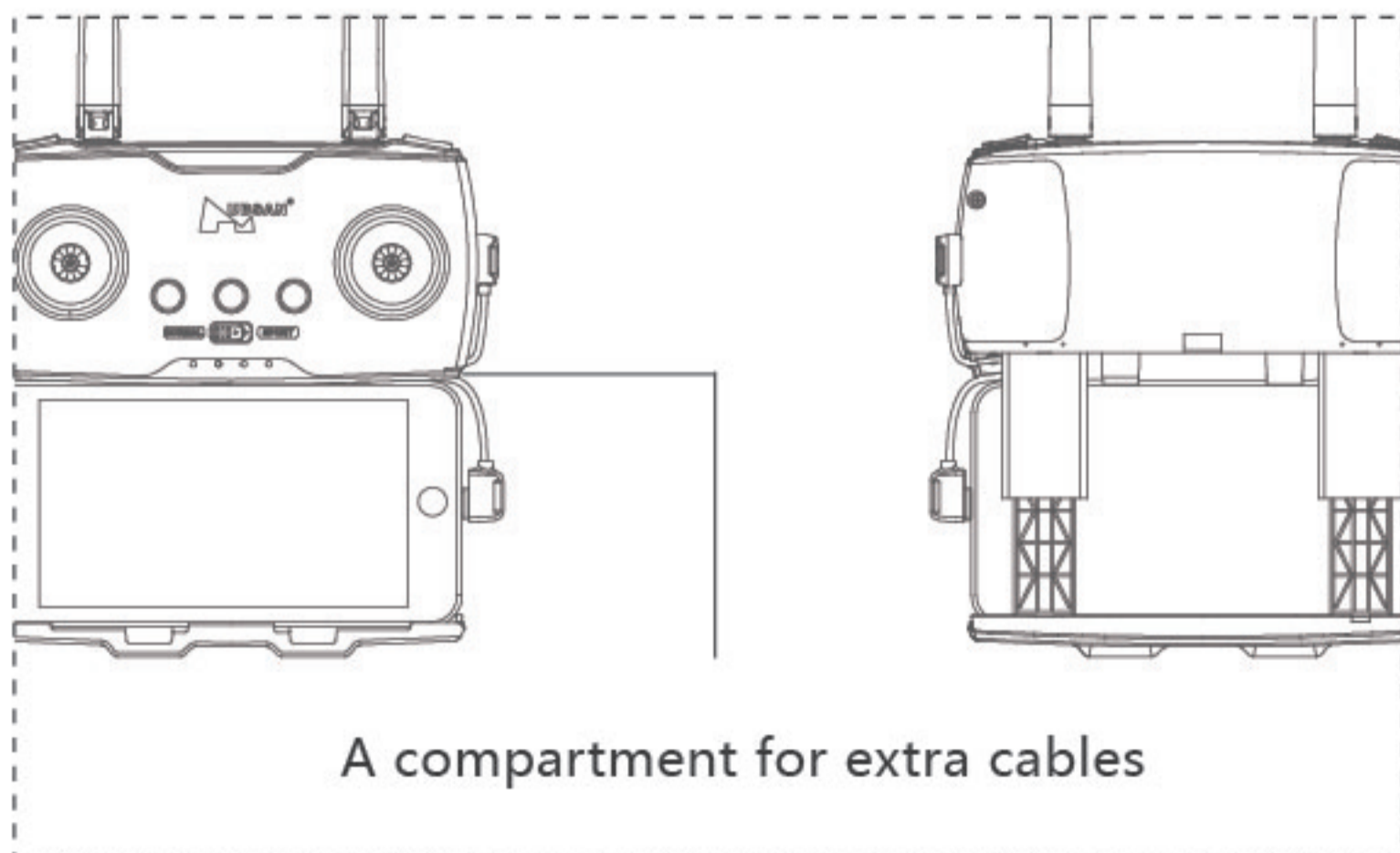



### 3.3 HT016B Function Breakdown

S/N	Key / Switch	Function
(1)	Throttle / Rudder Stick	Push the stick forward or backward and the quadcopter will ascend or descend (respectively). Push the stick left or right and the quadcopter will fly left or right (respectively).
(2)	Elevator / Aileron Stick	Push the stick forward or backward and the quadcopter will fly forwards or backwards (respectively). Push the stick left or right and the quadcopter will rotate counterclockwise or clockwise (respectively).
1	Throttle / Aileron Stick	Push the stick forward or backward and the quadcopter will ascend or descend (respectively). Push the stick left or right and the quadcopter will rotate counterclockwise or clockwise (respectively).
2	Elevator / Rudder Stick	Push the stick forward or backward and the quadcopter will fly forwards or backwards (respectively). Push the stick left or right and the quadcopter will fly left or right (respectively).
3	Return To Home	Long press to perform a Return to Home. Short press to terminate Return to Home.
4	Power Switch	Long press to power on or off.
5	Auto Takeoff / Land	Long Press to auto takeoff or land.
6	Normal / Sport Mode	Normal Mode (Left): Throttle 100%, Elevator 70%, Rudder 70%, Aileron 70%. Sport Mode (Right): Throttle 100%, Elevator 100%, Rudder 100%, Aileron 100%
7	Power Status LEDs	The 4 LEDs are battery indicators. Each LED represents 25% of the battery.
8	Photo	Short press to take photos. Long press to turn off LED indicators.
9	Video	Long press to start recording. Short press to end recording.
10	Gimbal Adjustment Wheel-Pitch	Controls the angle of the gimbal.
11	Transmitter Charging Port	Used to charge the transmitter.

### 3.4 Charging the Transmitter Battery

The HT016B transmitter can be charged with using a Micro USB cable as shown:

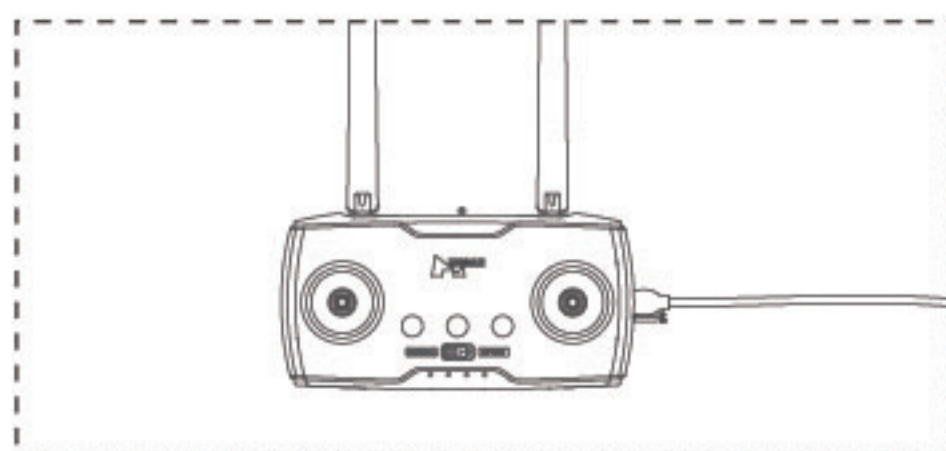



## 4 Flight

We recommend that users implement some kind of flight training (i.e using a simulator for flight practice, seeking professional guidance, etc.) before flying the aircraft. Please select an appropriate flight environment for flight.

### 4.1 Pre-Flight Checklist

- (1) The aircraft and transmitter batteries are fully charged.
- (2) Whether the propellers are installed correctly.
- (3) Insert a Micro-SD card for saving photos and videos.
- (4) Whether the motors start normally.
- (5) Make sure the camera lens is clean.

### 4.2 Pairing The Mobile Device

- ( 1 ) Long press the power button on the aircraft to power it on.
- ( 2 ) Long press the transmitter power button to power it on.  
Use the adapter cable to connect the transmitter to the aircraft.



Before Pairing



After Pairing



( 3 ) Run X-Hubsan App, In the main settings at the top right corner, select Control settings then choose WIFI and "Set up transmitter connection to aircraft" to set up the connection between aircraft and the transmitter.

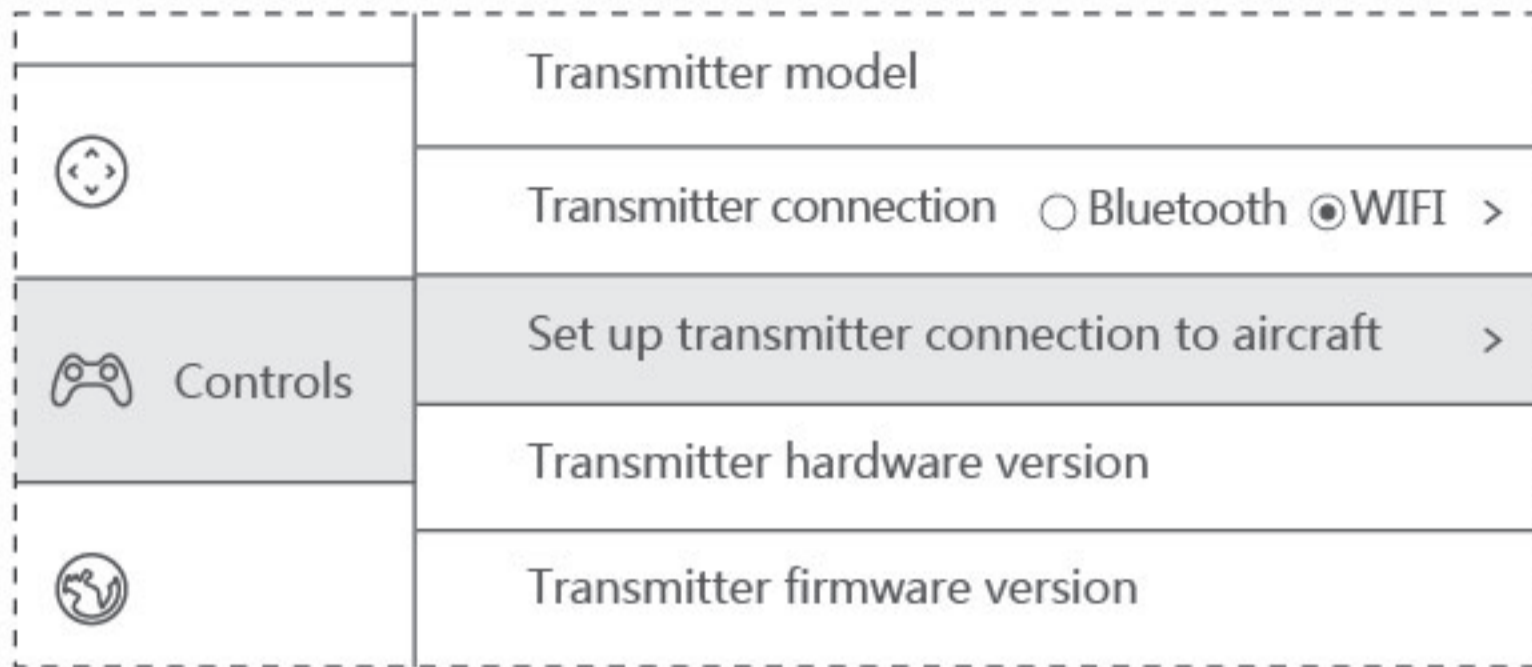

( 4 ) Refresh the WIFI list to search for the WIFI name of your product (Hubsan-Zino-XXXXXX). Tap on "Connect". After a successful connection, you can control the aircraft based on the prompts.

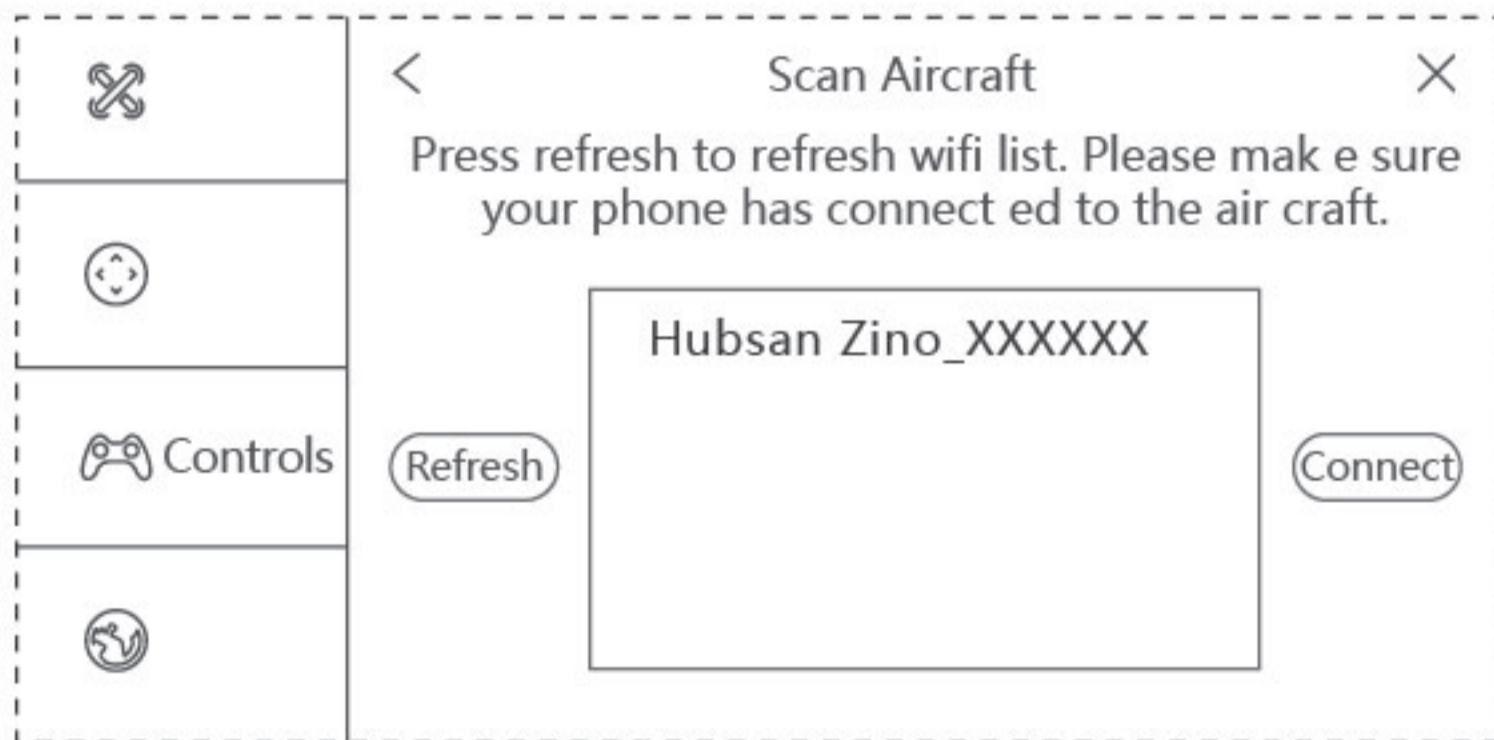



## 4.3 Calibration

### 4.3.1 Horizontal Calibration

If during takeoff or flight the aircraft drifts, lifts off unevenly, perform a horizontal calibration. First, land the aircraft if it is flying and make sure all motors come to a complete stop. The aircraft must also be on a completely flat and horizontal surface for the calibration to work properly. Tap the Settings cog, followed by "Other". Select "Horizontal Calibration" and allow the aircraft to calibrate itself. Calibration is complete when all 4 LED indicators stop flashing. Do not move the aircraft during calibration.

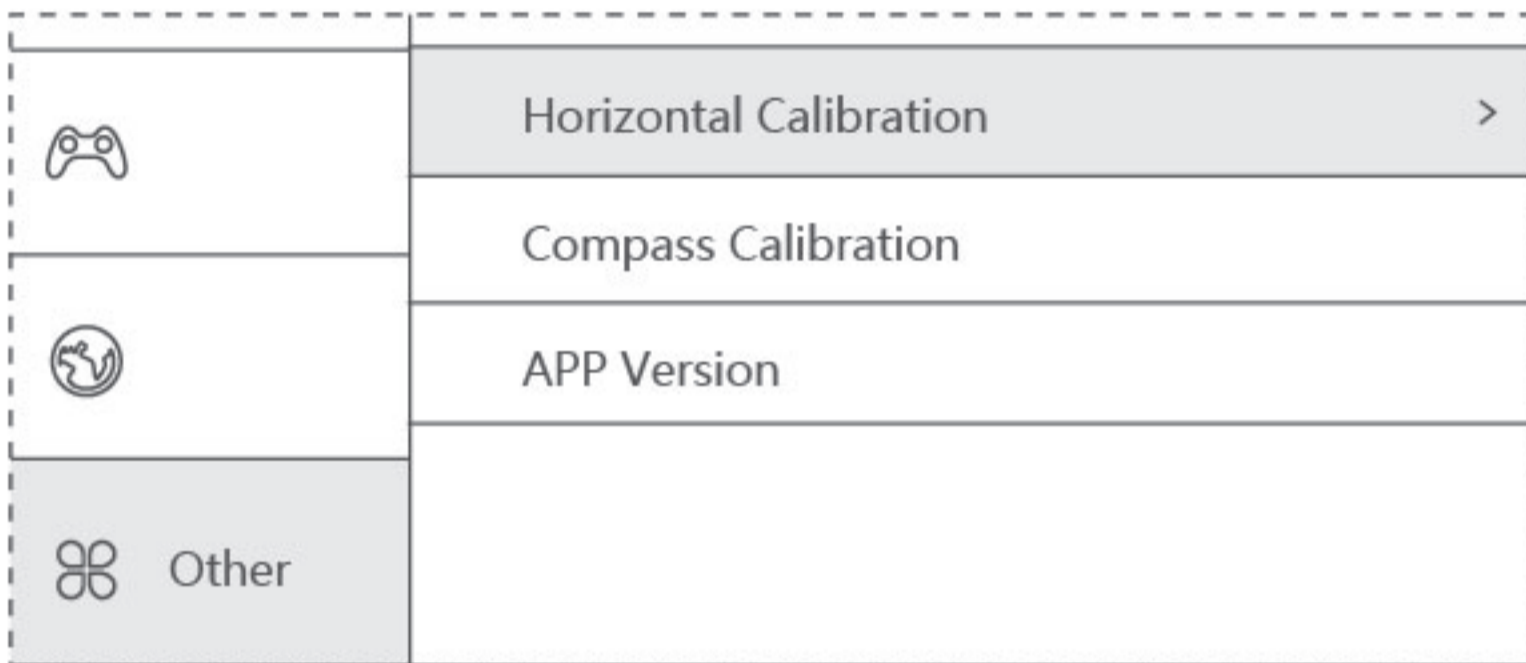

### 4.3.2 Compass Calibration

When using for the first time, the compass calibration will pop out before takeoff. Follow the instructions on your screen, rotate the aircraft horizontally then point the aircraft nose down and rotate it clockwise. The compass calibration message will disappear once it is completed. You must complete the compass calibration before flying the aircraft for the first time.

The compass is susceptible to interference by electronic equipments, magnetic interference and metals and interference could lead to erratic behavior and loss of control. Regular calibration helps to keep the compass and its readings accurate. To manually calibrate the compass, tap the "Settings" cog on the upper right hand corner of the main interface. Then select "Other" followed by "Compass Calibration".



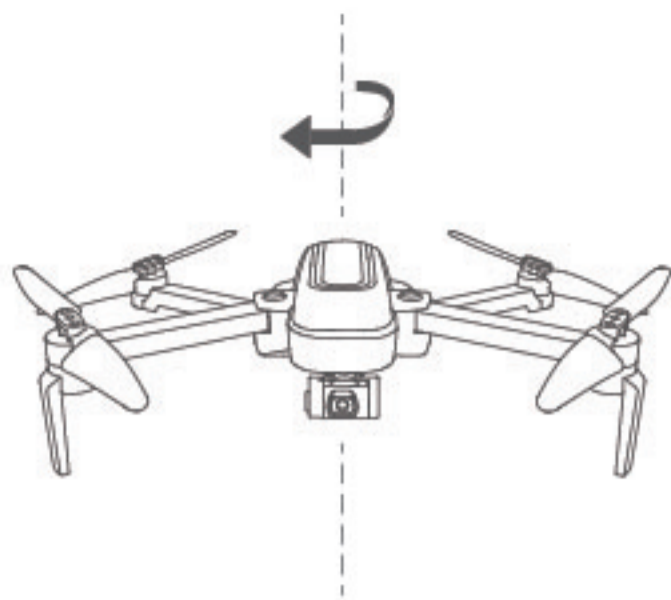

Compass 1

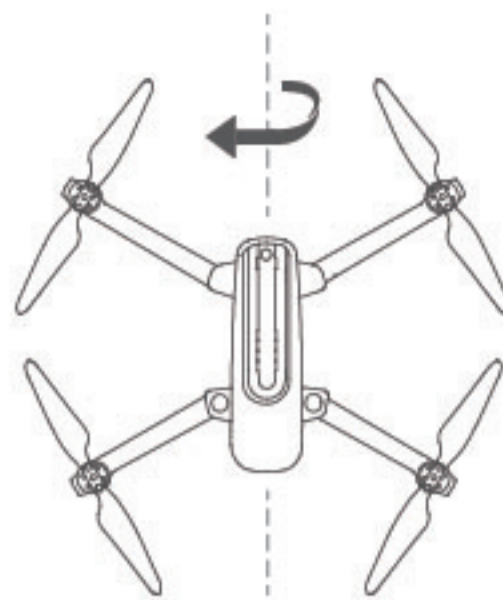

Compass 2

### 4.3.3 GPS Accuracy Test

After entering the APP interface, tap on "Aircraft", select "GPS Accuracy Test" then tap on "Enable / Restart GPS Accuracy Test". The aircraft will automatically proceed to test.

	Aircraft	
	Aircraft Name	
	Waypoint Parameter	>
	GPS Accuracy Test	>
	Devices Pairing	>
	Flight Control Version	
	Video Version	

	Aircraft	<	GPS Accuracy Test	
	Current GPS Accuracy		<input type="text" value="385288598..."/>	
	GPS Accuracy Test Timeout		<input type="text" value="15"/>	
	Start / Restart GPS Accuracy Test		>	



## 4.4 Flying with the APP

### 4.4.1 Auto Takeoff / Land

When the LED indicators are solid on the aircraft, pilots can use auto takeoff / land function. Please follow the steps below for auto takeoff / land:

#### Auto Takeoff

As shown in Figure 1, make sure the surrounding environment is safe for take off then tap on the "Auto Takeoff" button and the aircraft will take off and hover at 2 meters in altitude.

#### Return to Home / Auto Land

As shown in Figure 2, tap on the "Auto Land" button then the aircraft will enter Return mode. You can choose to return to the takeoff point, mobile device location or land at its current location.

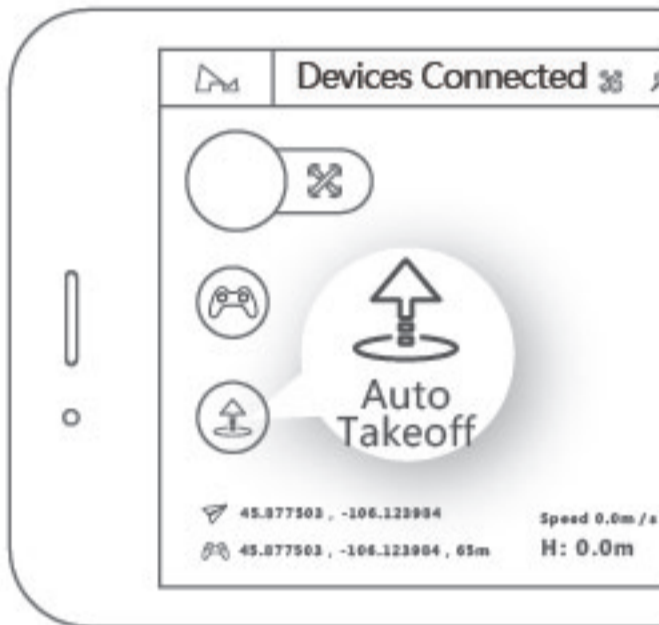

Figure 1

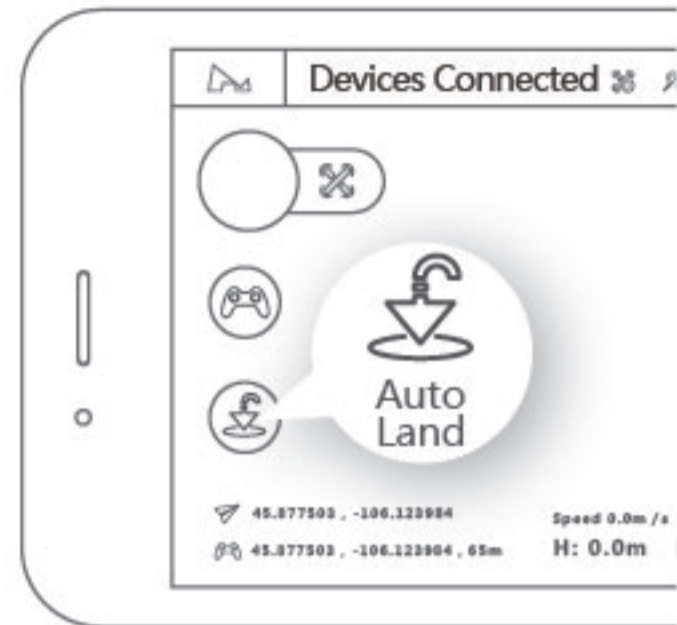
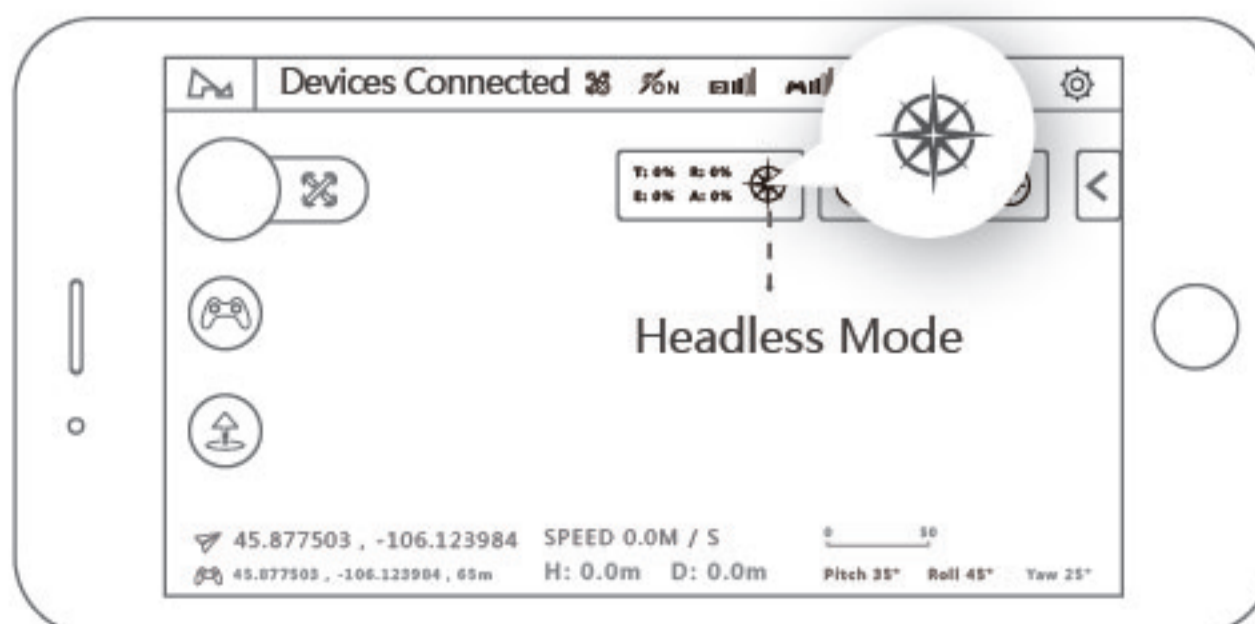

Figure 2

### 4.4.2 Advanced Functions

#### 1) Headless mode

Tap on the icon to enter / exit Headless mode. When Headless Mode is activated, the aircraft will use whichever direction its head is facing as the default forward position in Headless Mode.





## 2) Waypoints

In the APP settings, go to "Aircraft" - "Waypoint Parameter" to set the waypoint parameters.

Aircraft		Waypoint Parameter	
		Default Waypoint Altitude	30
		Maximum Waypoint Altitude	500
		Maximum Waypoint Length	1000
		Maximum Waypoint Radius	300
		Default Waypoint Hover Time	2
		Maximum Waypoint Hover Time	30

Tap on "Mode Selection" and select "Waypoint Mode". You may choose "Waypoint Planning" or "Waypoint Memory"

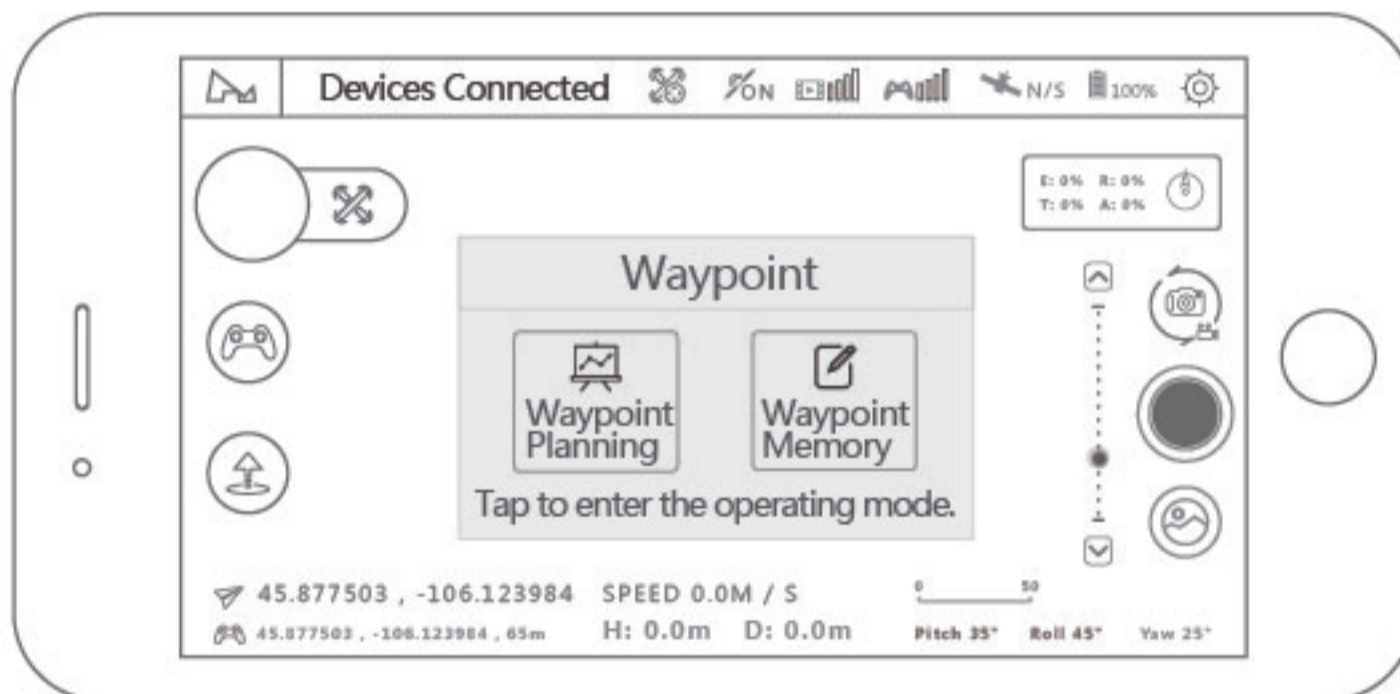

**Waypoint Planning:** You can preset the waypoint parameters such as the number of waypoints, the altitude of each waypoints and other parameters. The aircraft will follow the preset parameters after you activate waypoint mode. You can control the flying speed during flight or you can pause or resume the Waypoint mode.

**Waypoint Memory:** After entering the mode, fly the aircraft and tap on "Memorize Waypoints" on the APP and the aircraft will mark the location. After memorizing all the waypoints, upload and execute, then the aircraft will fly according to the memory.

**Point of Interest:** You can set a point of interest in Waypoint mode and the aircraft will always face the point of interest during flight. If the aircraft is not in the starting location, the aircraft will fly to the starting location first.



### 3) Orbit mode

Tap on "Mode Selection" then "Orbit Mode" to set the current location or the position of the mobile device as the center. During Orbit mode, you can adjust the speed and direction by moving the control stick left and right and adjust the orbit radius by moving the control stick forward and backward.

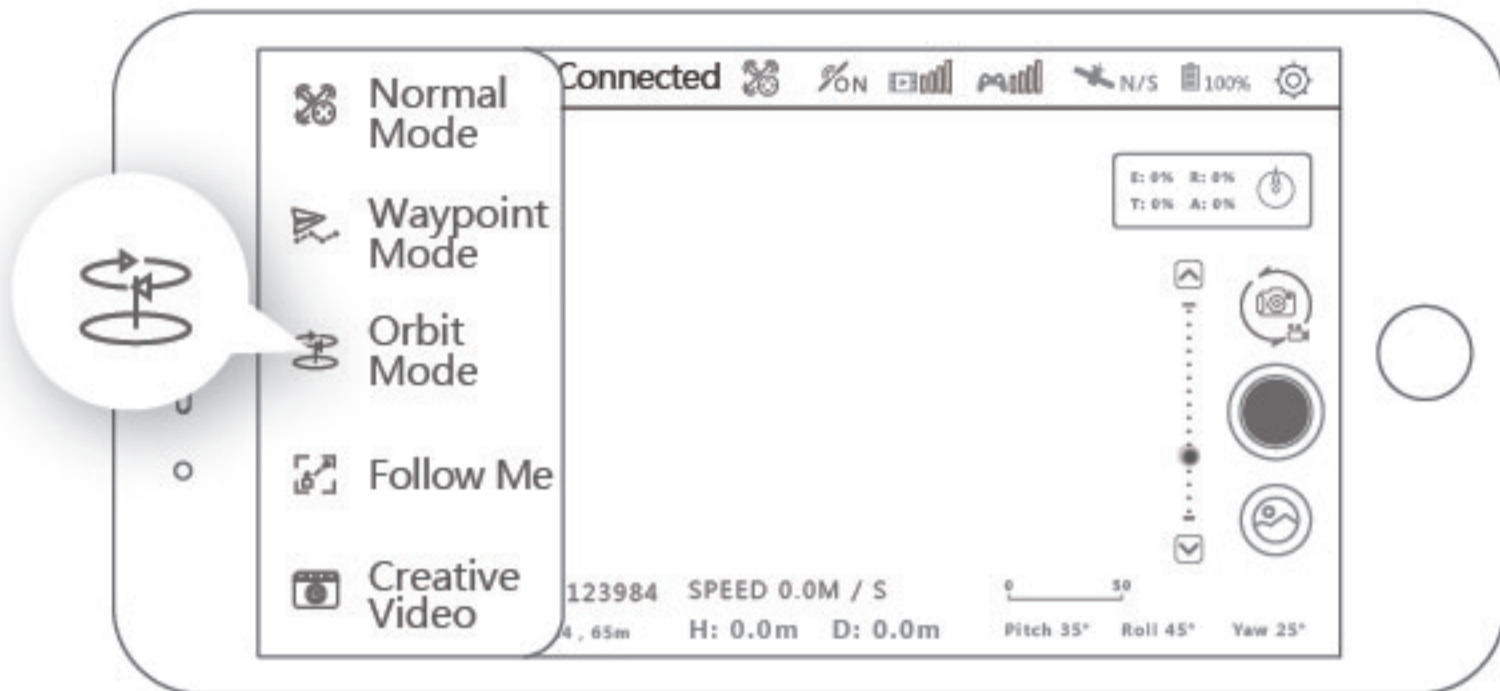

### 4) Follow Me

When the aircraft is hovering, Tap on "Mode Selection" then "Follow Mode" to choose "GPS Follow" or "Image Tracking".

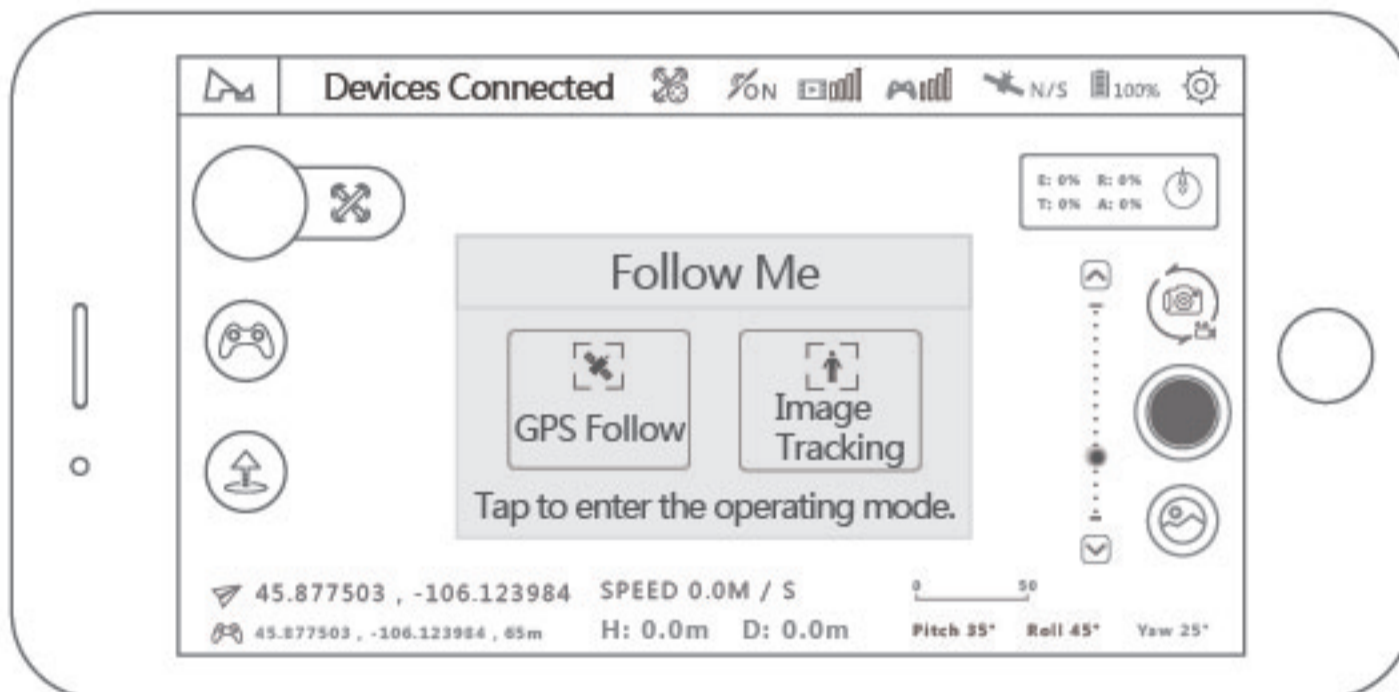

**GPS Follow:** Aircraft will follow the movements of the mobile device.

**Image Tracking:** Select the target on the APP. After the selecting successfully, tap on "Go" and the aircraft will follow the movements of the target. The range of tracking altitude and distance is 5-15 meters.



## 5 ) Creative Video

Tap on "Mode Selection" then "Creative Video" and select "Panorama". Set the direction, angle and speed of the aircraft rotation. Once the setup is complete, the aircraft will perform panorama recording and save the recording.

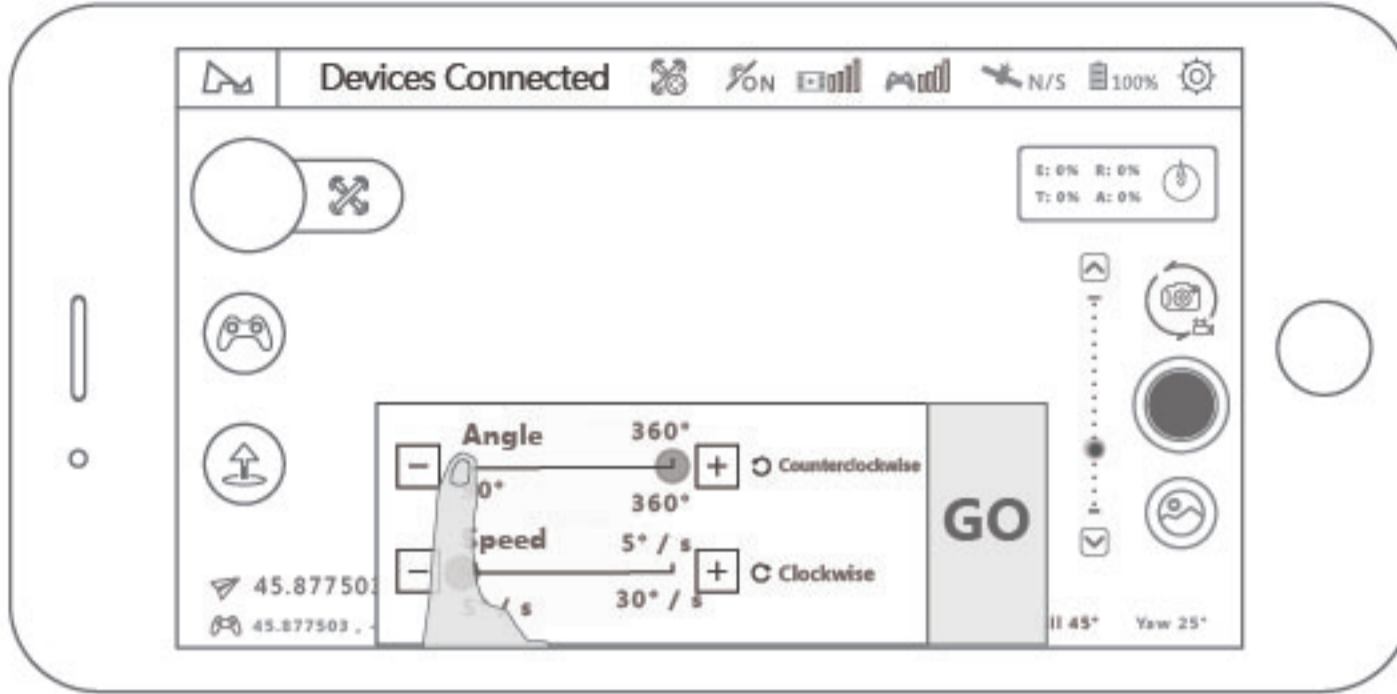

## 6 ) Line Fly Mode

Tap on "Mode Selection" then "Line Fly Mode". Set the angle, distance and speed of the aircraft. Once setup is complete, the aircraft will execute Line Fly mode. During the flight, pilots can take photos or videos manually, or pause / resume / stop the flight at any time.

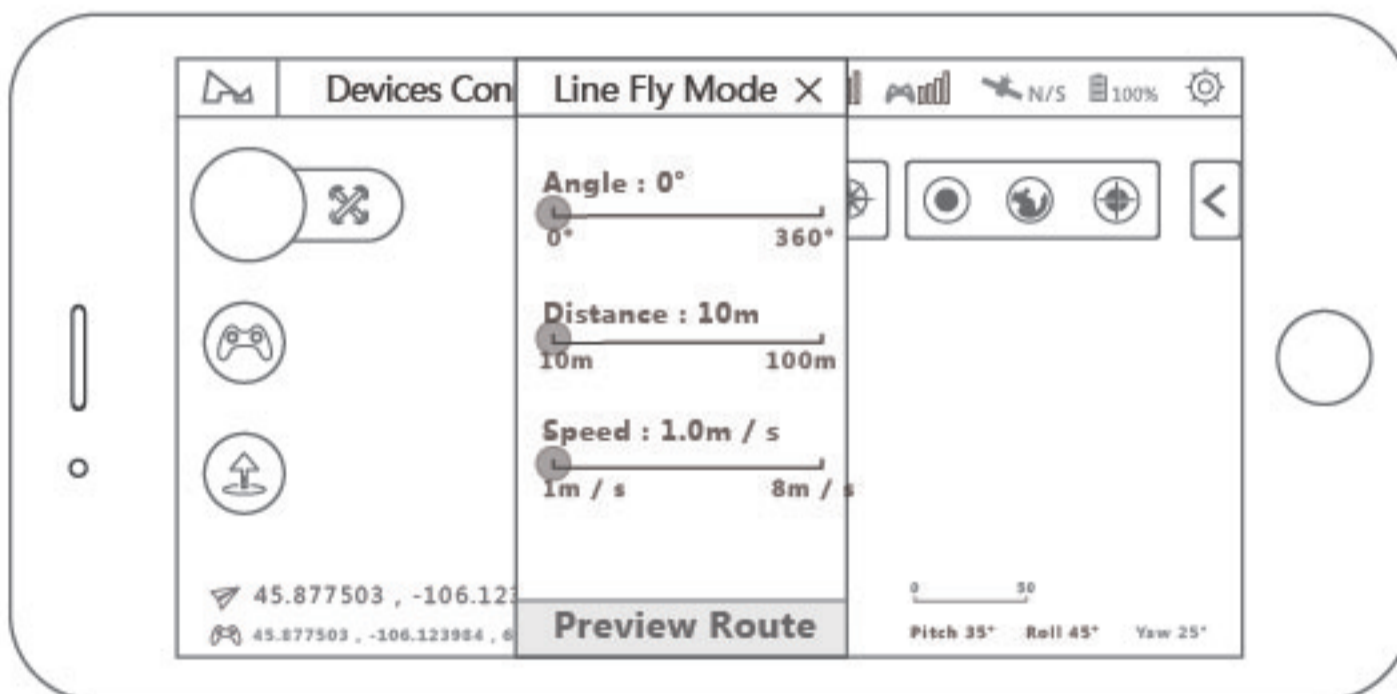

Advanced features can only be used after successfully passing GPS accuracy test.

When the aircraft is low on battery or lost connection, the aircraft will always set Return to Home as the priority mission.



## 4.5 Flying with the HT016B Transmitter

When your aircraft is connect to the mobile device and the transmitter, you can control the aircraft with the transmitter.

How to arm the motors:

Simultaneously pull the joysticks diagonally down-out to arm the motors (as shown in the below figure).

How to disarm the motors:

Disarm the motors by simultaneously pulling both sticks diagonally down-out. When the motors have completely stopped, release the joysticks.

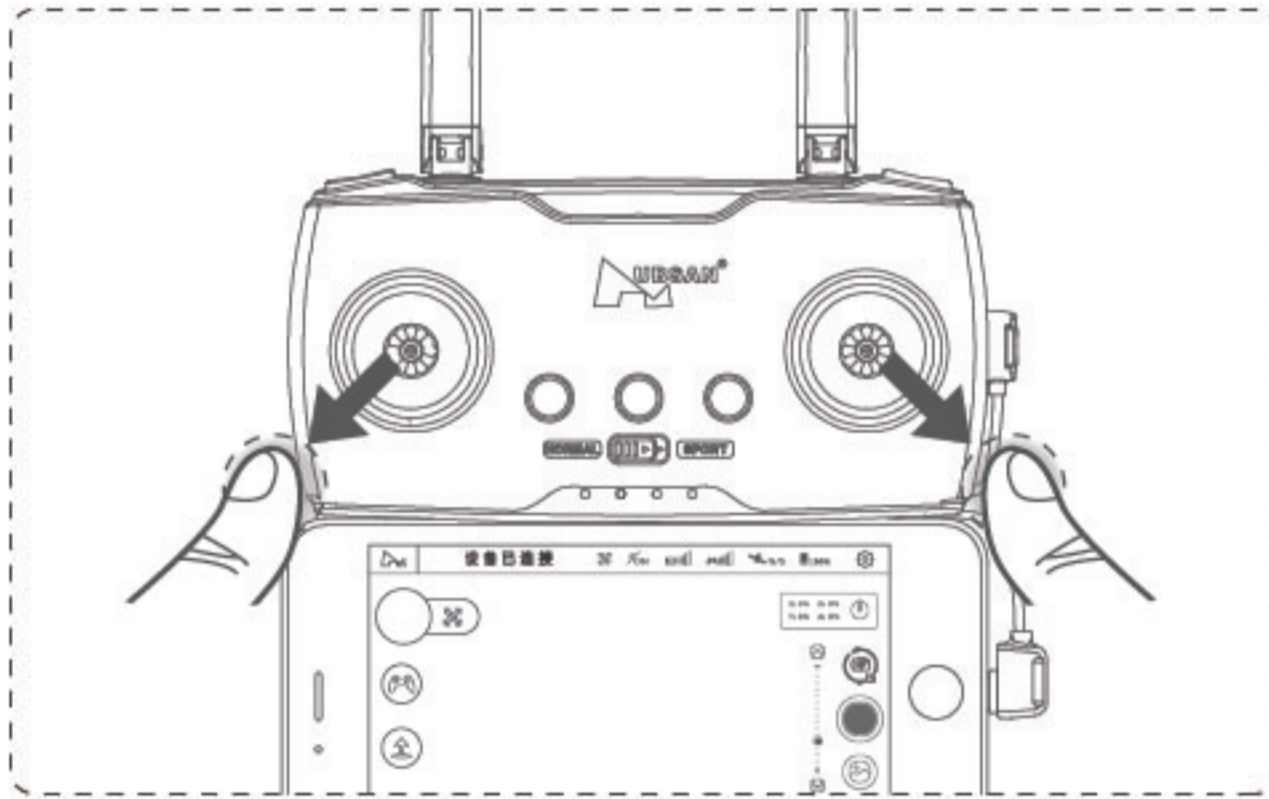

Motor Arming Condition:

1. The aircraft, transmitter and mobile device must be connected.
2. Compass Calibration must be completed (four solid LEDs).
3. The aircraft must be on a horizontal surface.

- ⊘ Do not pull the sticks diagonally down-out during flight, otherwise motors could stop and causing the aircraft to crash and other damages.
- 💡 When operating, gently control the joystick; after arming / disarming the motors, release the joysticks.



## Auto Takeoff / Land

When the aircraft LED indicators stay solid, pilots can use auto takeoff / land. Please follow the instructions below for auto takeoff / land:

### Auto Takeoff

Make sure the surrounding environment is safe for takeoff. Long press the auto takeoff button and the aircraft will take off automatically and hover at the 2 meters in altitude.

### Auto Land

Make sure the surrounding environment is safe for landing. Long press the auto land button and the aircraft will land automatically and disarm the motors.

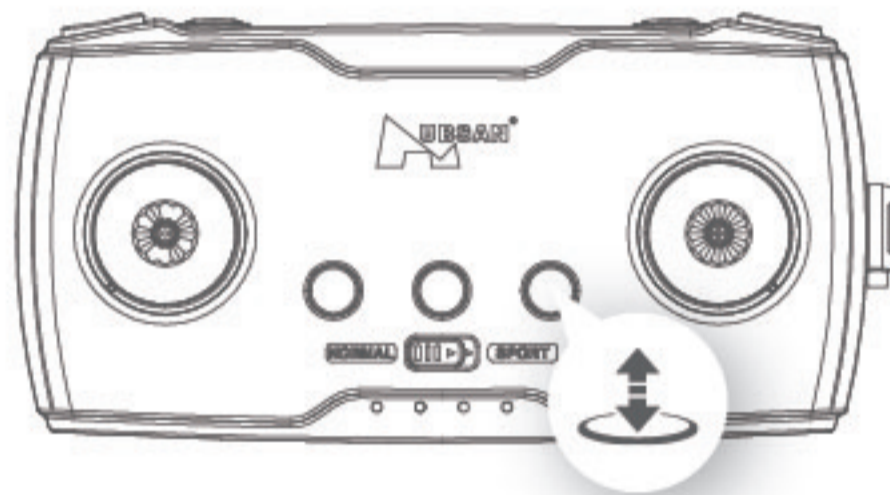

## Automatic Return

This feature needs 6 or more GPS satellites prior to takeoff, otherwise it cannot return to the takeoff point.

### Entering Automatic Return Mode

Press and hold the "Automatic Return" button for 1.5 seconds for the aircraft to enter Automatic Return. The flight control system will automatically control the aircraft to fly back to the home point and land.

### Exiting Automatic Return Mode

Short press the "Automatic Return" button for 0.5 seconds to exit Automatic Return. You will regain control and control the aircraft with the transmitter.

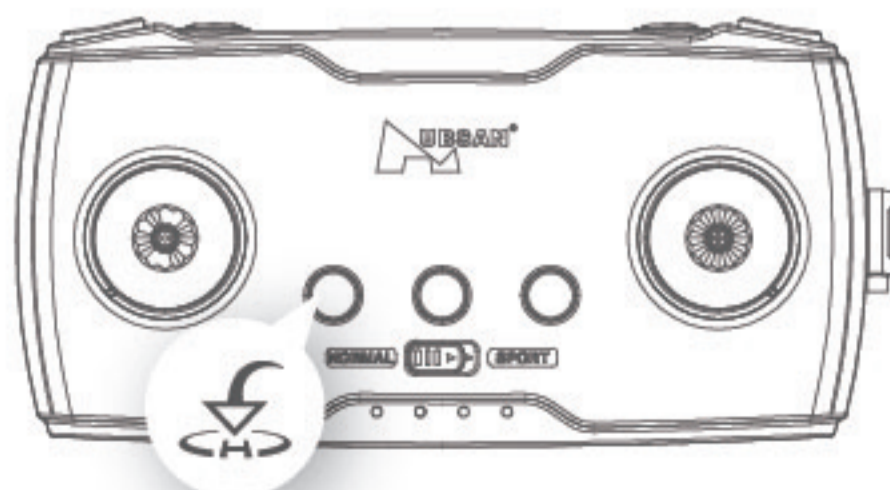



The remote control is by default set to Mode 2 in factory; this manual will introduce flight operations in Mode 2.

- Transmitter joysticks are self-centering and spring loaded: the joysticks will automatically center themselves
- Joystick sensitivity: dependent how much and how forcefully each joystick is pulled or pushed away from center point.

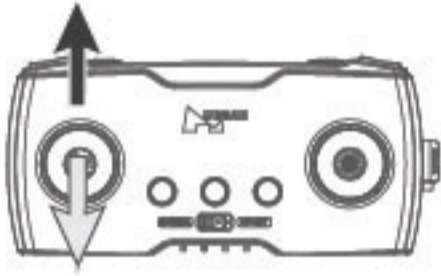
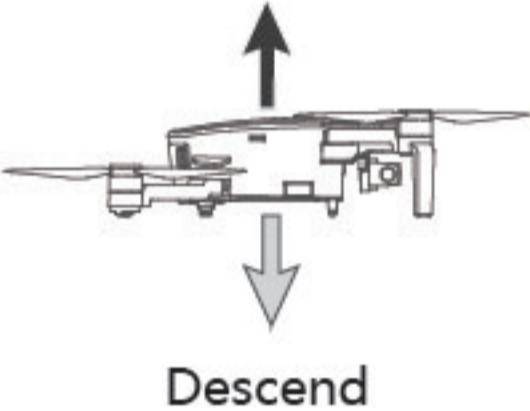
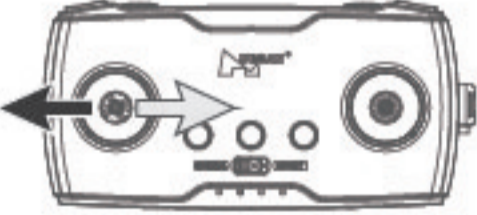
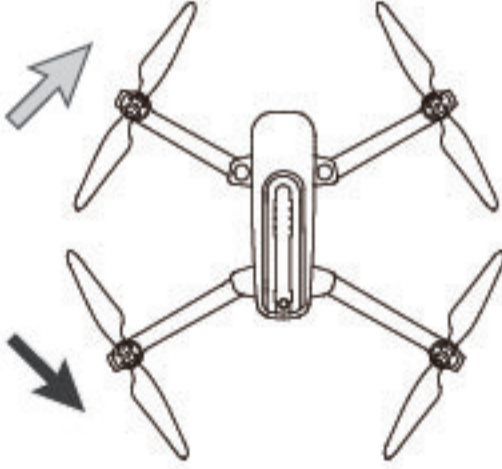
Remote Control (Mode 2)	Aircraft	Transmitter controls
	<p style="text-align: center;">Ascend</p>  <p style="text-align: center;">Descend</p>	<p>The throttle is used to control the ascent and descent of the aircraft. Push the throttle up and the aircraft ascends. Pull the throttle back and the aircraft descends. When the joystick is centered (unmoving), the aircraft will hold its altitude in the air. The throttle must be pushed upwards beyond center point for the aircraft to completely takeoff from the ground. The harder the throttle is pushed, the faster the aircraft will ascend. Please push the throttle slowly for a gradual lift and to prevent the aircraft from ascending erratically.</p>
	<p style="text-align: center;">Clockwise rotation</p>  <p style="text-align: center;">Counterclockwise rotation</p>	<p>The rudder is used to control the aircraft's rotations. Push the joystick to the left and the aircraft rotates counterclockwise. Push the joystick to the right and the aircraft rotates clockwise. When the joystick is centered (unmoving), the angular velocity of the aircraft is "0" and the aircraft will not turn. How hard the rudder is pushed will determine the angular velocity of the aircraft's rotation. The harder the rudder is pushed, the faster the aircraft rotates.</p>

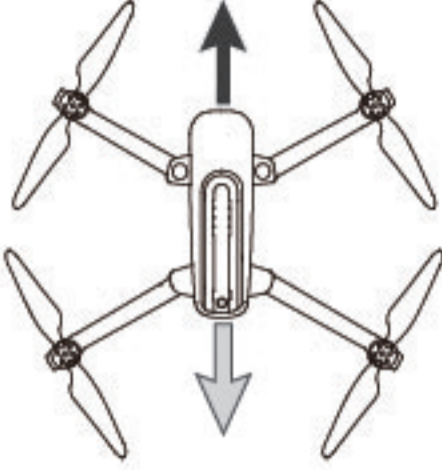
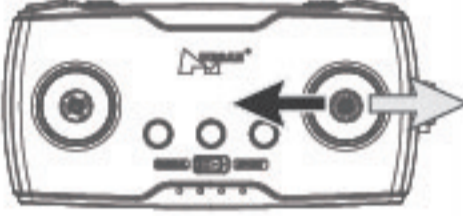
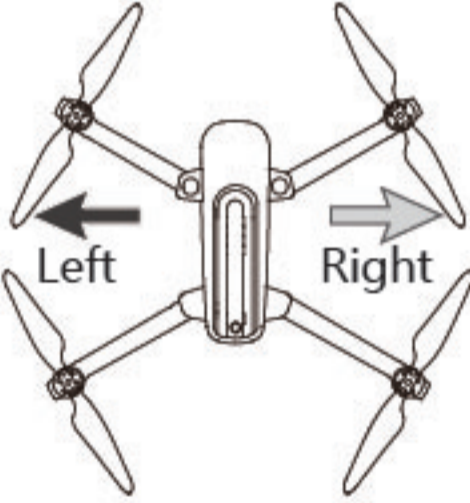

Remote Control (Mode 2)	Aircraft	Transmitter controls
	<p data-bbox="771 464 950 511">Forward</p>  <p data-bbox="757 997 964 1044">Backward</p>	<p data-bbox="1135 332 1815 1279">The elevator controls the aircraft's forward and backward movement. Push the joystick forward and the aircraft will tilt and fly forward. Pull the joystick back and the aircraft will tilt and fly backwards. When the joystick is centered (unmoving), the aircraft will hold its altitude in the air. How hard the elevator is pushed will determine the degree of the aircraft's tilt and therefore the velocity of its forward and backward movement. The harder the elevator is pushed, the greater the aircraft's tilt angle and flight speed either forwards or backwards.</p>
	 <p data-bbox="671 1884 751 1931">Left</p> <p data-bbox="930 1884 1009 1931">Right</p>	<p data-bbox="1135 1430 1815 2377">The aileron controls the aircraft's left and right movement. Push the joystick to the left and the aircraft will tilt and fly leftwards. Pull the joystick to the right and the aircraft will tilt and fly rightwards. When the joystick is centered (unmoving), the aircraft will hold its altitude in the air. How hard the aileron is pushed will determine the degree of the aircraft's tilt and therefore the velocity of its left and right movement. The harder the aileron is pushed, the greater the aircraft's tilt angle and flight speed either leftwards or rightwards.</p>



## 5 Failsafe

### 5.1 Low Power Failsafe

When the aircraft battery is low, there is likely insufficient power to support the return of the aircraft. Please land the aircraft immediately, otherwise the aircraft will fall and cause damage to the aircraft and surrounding objects. To prevent this, the aircraft flight control will use flight information to determine whether to perform a Return to Home or to land immediately.

### 5.2 Loss Of Flight Control Failsafe

When the flight control connection between the aircraft and transmitter is lost, the aircraft will automatically land or return to where the remote control / transmitter was last located and land there. This can drastically reduce the possibility of the aircraft crashing or being lost.

Conditions that may trigger a failsafe

- 1) Transmitter is powered off / loses power.
- 2) The flight distance exceeds the remote control' s signal transmission range.
- 3) There is an obstacle between the remote control and aircraft.
- 4) The flight control or transmitter signal is interrupted by strong external electronic interference.



To ensure the successful return of the aircraft if it loses flight control connection, users must confirm that the aircraft has enough GPS satellites to fly safely in GPS mode. Users must also be certain that the flight environment is clear enough for an emergency return and landing.

If the aircraft's GPS satellites drop below 6 for more than 20 seconds while the X4 is returning to Home Point, the aircraft will automatically descend.



# Frequently Asked Questions

## **1. Aircraft and remote control are not pairing**

- ① Check that the mobile device WIFI utility is active.
- ② Restart the aircraft.

## **2. Weak or nonexistent GPS signal / few or no GPS satellites**

Make sure that the aircraft is not indoors or between buildings. Please take the aircraft outdoors to receive GPS satellites / signal.

## **3. The aircraft does not return to the home point**

When the aircraft takes off, be sure that the aircraft has received 6 or more satellites.

## **4. Aircraft / video feed is shaking / shaky**

- ① Check if the aircraft propellers are deformed or broken. Please replace them.
- ② Check that all aircraft body screws are firmly in place.
- ③ Check whether the gimbal is performing normally.

## **5. Aircraft refuses to pass the GPS accuracy test (even after a long wait)**

- ① Restart the test from the Settings interface ("Other") and move the mobile device around the drone (you must be within 1-3 feet of the aircraft for this to work)
- ② Rebind / re-pair the mobile device and aircraft

## **6. Aircraft video software upgrade precaution**

- ① Does not support EXFAT32 formate SD cards.
- ② During the upgrade, the power cannot be cut off.

## **7. Android phone and transmitter cannot be connected**

Please visit the official website or the APP Flight Academy to download "Connecting Tutorial for Android Phones"



# Parts & Accessories



Zino00-01  
Gimbal Cover



Zino00-02  
WIFI Antenna



Zino00-03  
Main Board

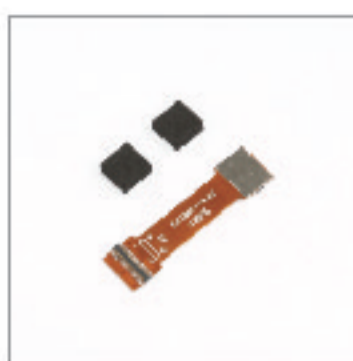

ZinoA00-04  
Power Adapter  
Board FPC



Zino00-05  
Keypad FPC



Zino00-06  
Compass  
Module

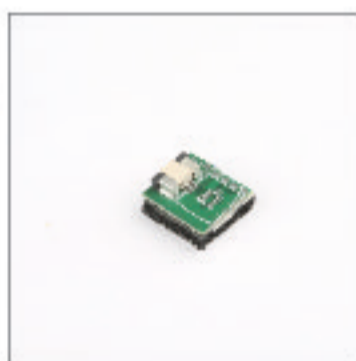

Zino00-07  
Gyro Module



Zino00-08  
Gyro FPC



Zino00-09  
GPS Module



Zino00-10  
HT016B  
Transmitter.



Zino00-11  
Micro USB  
Adapter Cable



Zino00-12  
Type C  
Adapter Cable



Zino00-13  
iPhone  
Adapter Cable



Zino00-14  
Decorative  
Stickers



Zino00-01  
Upper Cover



Zino00-02  
Top Shell



Zino00-03  
Power  
Button + LED



Zino00-04  
Bottom Shell



Zino00-05  
Power Board  
Clamp + Gimbal  
Anti-drop Parts



Zino00-06  
Arm Cover

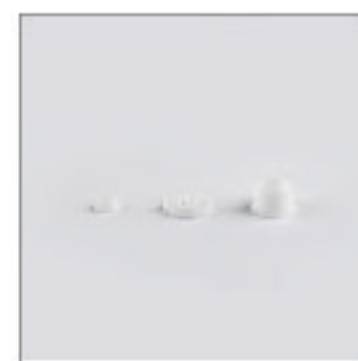

Zino00-07  
Pressing + Swivel  
+ Bushing Parts



Zino00-08  
Translucent  
Parts



Zino00-10  
Gimbal  
Protection Cover



Zino00-11  
Propeller  
Clamps



Zino00-12  
Antenna Cover



# Parts & Accessories



Zino00-13  
Arm Decoration  
+ Clamp



Zino00-14  
Foot Pads



Zino00-15  
Gimbal Shock  
Absorbers



Zino00-16  
Arm  
Shrapnel



Zino00-17  
Propeller A  
(with screws)



Zino00-18  
Propeller B  
(with screws)



Zino00-19  
Long Cable Motor  
(long screws)



Zino00-20  
ESC (Blue)



Zino00-21  
ESC (Red)



Zino00-24  
Power  
Adapter Board



Zino00-25  
Button Board

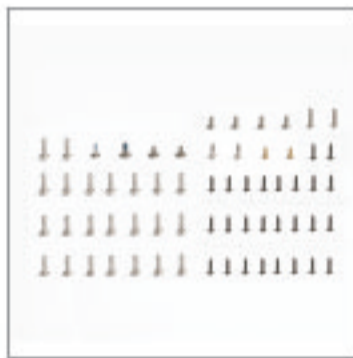

Zino00-26  
Screws



Zino00-27  
Screwdriver



Zino00-28  
LiPo Battery



Zino00-29  
Aircraft  
Battery Charger



Zino00-30  
Adapter



Zino00-31  
Balance  
Charger



Zino00-33  
USB  
Charging Cable



Zino00-36  
Short Cable  
Motor



Zino00-37  
Adapter (Euro)



Zino00-38  
Adapter (US)



Zino00-39  
Adapter (Aus)



Zino00-40  
Adapter (Jap)



## **Limitation of Liability**

Hubsan accepts no liability for damages, injuries or any legal responsibilities incurred directly or indirectly from the use of Hubsan products under the following conditions:

1. Damages, injuries or any legal responsibilities incurred when users are drunk, under the influence of drugs or anesthesia, dizzy, fatigued, nauseous and / or affected by other conditions both physical and mental that could impair sound judgment and / or personal ability.
2. Subjective misjudgment and / or intentional mis-operation of products.
3. Any and all mental damage, trauma, impairment, illness, compensation caused / solicited by accidents involving Hubsan products.
4. Product operation in no-fly zones (i.e. natural reserves).
5. Malfunctions or problems caused by modification, refit, replacement or use with non-Hubsan accessories / parts, failure to follow the guidance of the manual in assembly or operation.
6. Damages, injuries or any legal responsibilities caused by mechanical failures due to natural wear and tear (aircraft flight time clocking in 100 hours or above), corrosion, aging hardware, etc.
7. Continued flight after low voltage protection alarms are triggered.
8. Knowingly flying aircraft under abnormal conditions (such as when water, oil, soil, sand or other unknown material are inside the X4, the aircraft and / or transmitter are incompletely assembled, the main components have obvious faults, obvious defect or missing accessories, etc).
9. Flying in the following situations and / or environments: areas with magnetic interference (such as high voltage lines, power stations, broadcasting towers and mobile base stations), radio interference, government regulated no-fly zones, if the pilot loses sight of the X4, suffers from poor eyesight or is otherwise unsuited for operating Hubsan products.
10. Aircraft use in or exposure to bad weather, such as a rain, wind, snow, hail, lightning, tornadoes and hurricanes.
11. Products are involved in / exposed to collisions, fire, explosions, floods, tsunamis, manmade and / or natural structure collapses, ice, avalanches, debris, landslides, earthquakes, etc.
12. The acquisition, through use of Hubsan products (specifically but not limited to aircraft), of any data, audio, video that results in infringement of law and / or rights.



13. Misuse and / or alteration of batteries, product / aircraft circuits, hardware protections (including protection circuits), RC model and battery chargers.

14. Any malfunction of equipment or accessory, including memory cards, that results in the failure of an image or video to be recorded or not be recorded in a way that is machine readable.

15. Users who engage in reckless, unsafe flying (with or without sufficient training).

16. Non compliance with pre cautions, instructions, information and operation guidelines / methods given through official Hubsan website announcements, product quick start guides, user manuals, etc.

17. Other losses, damages, or injuries that are not within the boundaries of Hubsan responsibility.

RISK OF EXPLOSION IF BATTERY IS REPLACED BY AN INCORRECT TYPE.

DISPOSE OF USED BATTERIES ACCORDING TO THE LOCAL REGULATIONS.

HAZARDOUS MOVING PARTS KEEP FINGERS AND OTHER BODY PARTS AWAY.

### **Declaration of Conformity**

Hereby, SHENZHEN HUBSAN TECHNOLOGY CO., LTD.,

declares this product is in compliance with the essential requirements and other relevant

provisions of Directive 2014 / 53 / EU. A copy of the original Declaration of Conformity can be obtained at the following address: 13th Floor, Bldg 1C, SHENZHEN NANSHAN SOFTWARE INDUSTRY BASE, Xuefu Road, Nanshan District, Shenzhen, China

This product bears the selective sorting symbol for waste electrical and electronic equipment (WEEE). This means that this product must be handled pursuant to European Directive 2012 / 19 / EU in order to be recycled or dismantled to minimize its impact on the environment.

For further information, please contact your local or regional authorities. Electronic products not included in the selective sorting process are potentially dangerous for the environment and human health due to the presence of hazardous substances.



## FCC INFORMATION

This equipment has been tested and found to comply with the limits for a Class B digital device, pursuant to Part 15 of the FCC Rules. These limits are designed to provide reasonable protection against harmful interference in a residential installation. This equipment generates, uses, and can radiate radio frequency energy and, if not installed and used in accordance with the instructions, may cause harmful interference to radio communications. However, there is no guarantee that interference will not occur in a particular installation. If this equipment does cause harmful interference to radio or television reception, which can be determined by turning the equipment off and on, the user is encouraged to try to correct the interference by one or more of the following measures:

- Reorient or relocate the receiving antenna.
- Connect the equipment into an outlet on a circuit different from that to which the receiver is connected.
- Consult the local dealer or an experienced radio / TV technician for help.

Changes or modifications not expressly approved by the party responsible for compliance could void the user's authority to operate the equipment.

This device complies with Part 15 of the FCC Rules. Operation is subject to the following two conditions: (1) this device may not cause harmful interference, and (2) this device must accept any interference received, including interference that may cause undesired operation.

### **Electrical and electronic equipment that are supplied with batteries (including internal batteries)**

#### **WEEE Directive & Product Disposal**

At the end of its serviceable life, this product should not be treated as household or general waste. It should be handed over to the applicable collection point for the recycling of electrical and electronic equipment, or returned to the supplier for disposal. Internal / Supplied Batteries.

This symbol on the battery indicates that the battery is to be collected separately. This battery is designed for separate collection at an appropriate collection point.





## Please read the operating instructions carefully before use!

- Never leave units unattended when charging
- Unplug the charging cable immediately after charging
- Propellers may cause injury
- This product is not a toy
- Not suitable for children under 14 years of age



APP Flight  
Academy

Product name: X4 AIR PRO

Product Standard Number:Q/HBS 001-2017

Vendor: Shenzhen Hubsan Technology Co., Ltd

Address: 13th Floor, Block C, Shenzhen Software  
IndustrialBase, Xuefu Road, Nanshan District, Shenzhen,

Guangdong Province, China

Email: [service@hubsan.com](mailto:service@hubsan.com)

[WWW.HUBSAN.COM](http://WWW.HUBSAN.COM)